

MASSACHUSETTS INSTITUTE OF TECHNOLOGY
HAYSTACK OBSERVATORY
 WESTFORD, MASSACHUSETTS 01886
 September 16, 2013

Telephone: 781-981-5400
Fax: 781-981-0590

To: VSRT Group
 From: Alan E.E. Rogers
 Subject: Use of DVB-T RTL2832U dongle with Rafael R820T tuner

Figure 1 shows the block diagram of the ozone spectrometer using the R820T TV dongle to replace the DA4020/12 PCI bus ADC card. For compatibility with the existing ozone spectrometers a sample rate of 2.5 Ms/s was chosen. Since the samples are complex this covers a 2.5 MHz spectrum.

To avoid the edges of the bandpass only the central 1.25 MHz is used. Within the central 1.25 MHz the ozone line is frequency switched from -0.3125 to +0.3125 MHz from the center. In each switch position, the other position is used as reference. This scheme cancels most of the bandpass variations and only increases the noise by $\sqrt{2}$ compared with a fixed “total power” spectrometer. Since the ozone line is very weak bandpass normalization is obtained by dividing by the reference spectrum.

$$T(\nu) = (S(\nu) - R(\nu)) / R(\nu)$$

$$T_{line}(\nu) = (T(\nu) - T(\nu + \Delta)) / R(\nu)$$

$S(\nu)$ = “signal” spectrum

$R(\nu)$ = “reference” spectrum

Δ = frequency shift

The frequency drifts of the dongle and the LNBF L.O. are corrected by the signal from a harmonic of 10 MHz at 11070 MHz which is observed in place of the ozone line once per minute. As in the original spectrometer this signal has to be turned off while observing the ozone line to avoid the weak spurious signal which result from imperfections in the down conversion and ADC. This is accomplished using the USB switch shown in Figure 1.

Figure 2 shows a sample spectrum of the ozone line at 11.072 GHz taken at Haystack Observatory. The line is relatively weak this time of year. In addition much of the data from this 2 week period was excluded owing to interference from the radar nearby.

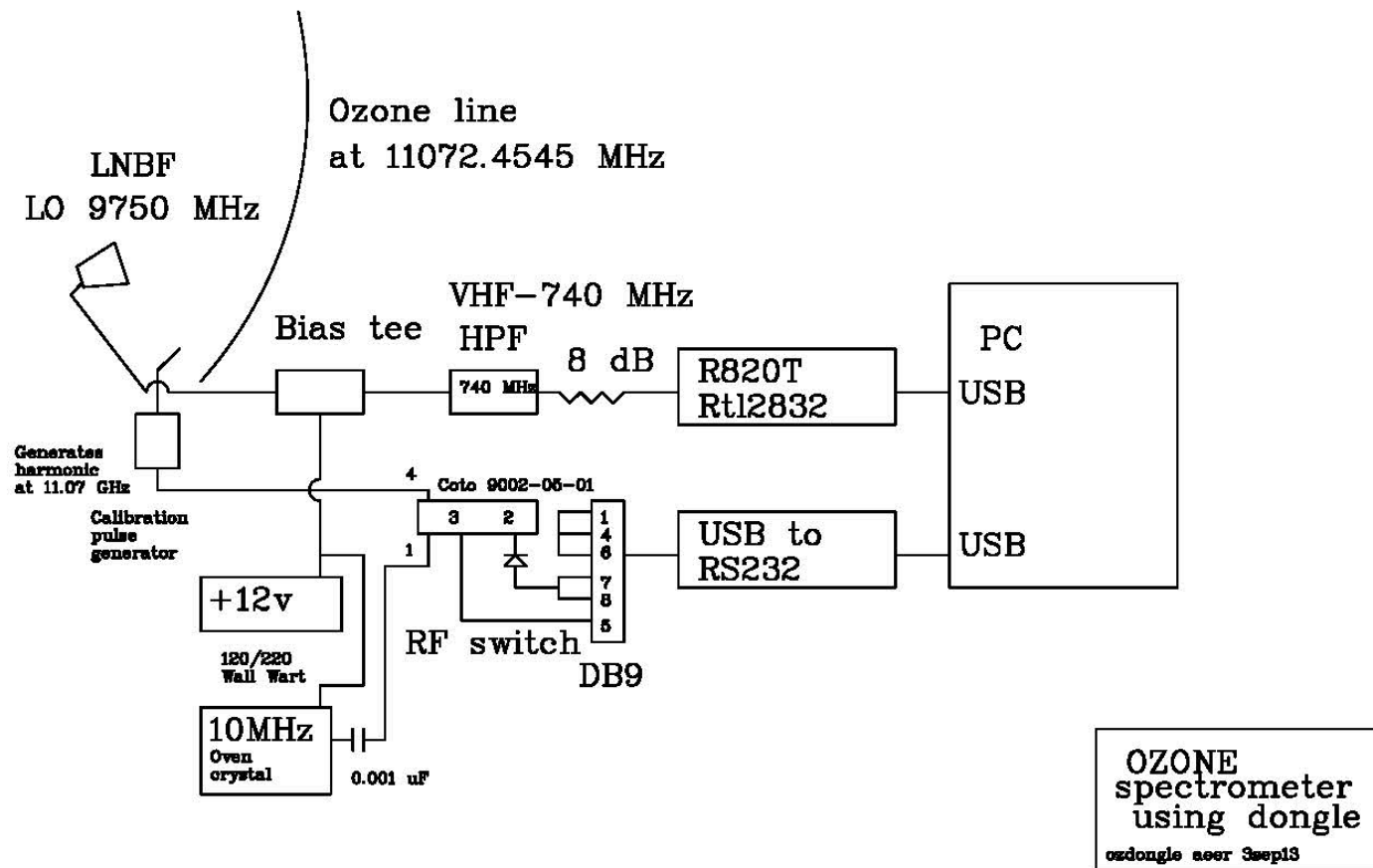

Figure 1. Block diagram of Ozone spectrometer using TV dongle.

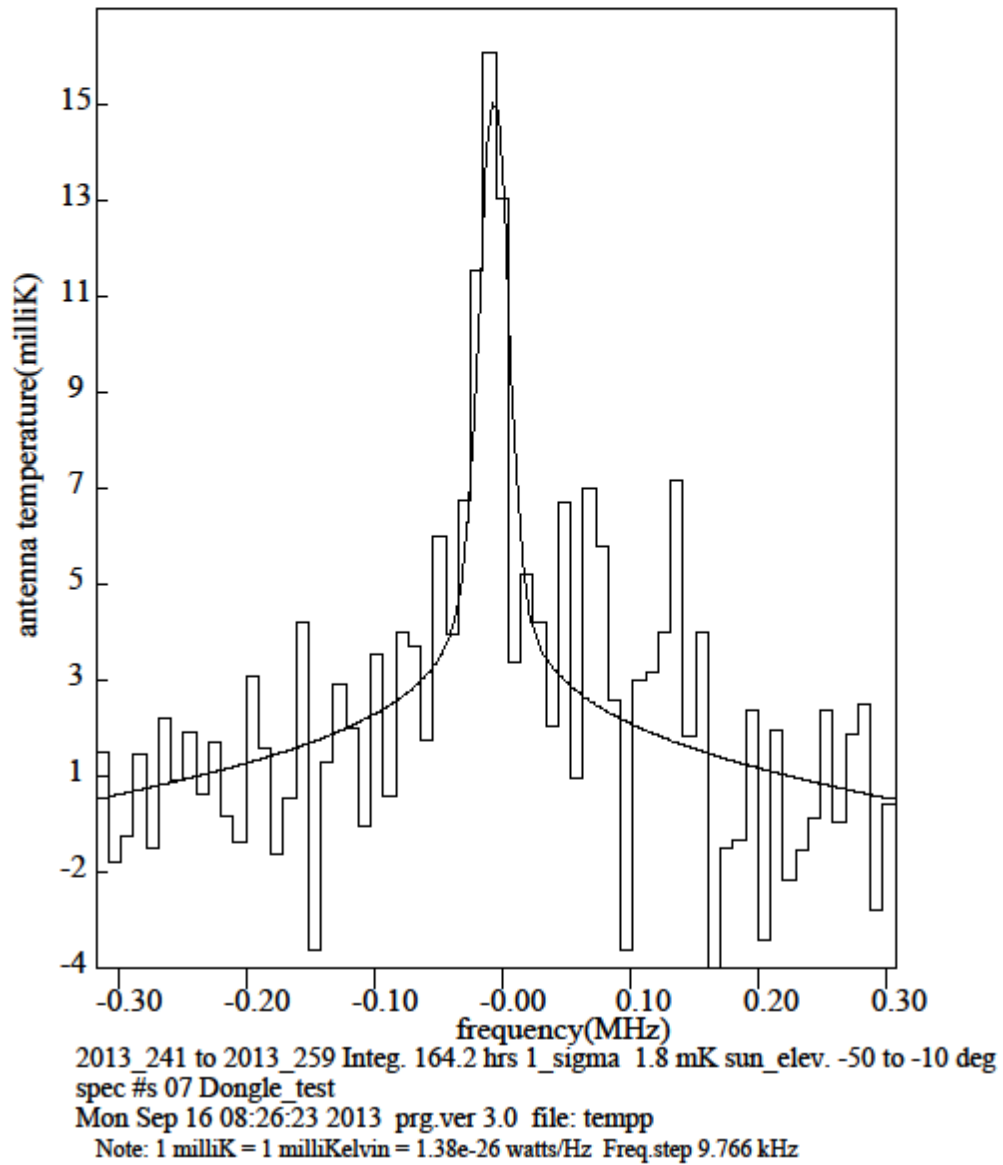

Figure 2. Sample spectrum from ozone line at 11.072 GHz.