

**MASSACHUSETTS INSTITUTE OF TECHNOLOGY**  
**HAYSTACK OBSERVATORY**  
**WESTFORD, MASSACHUSETTS 01886**  
 May 3, 2010

*Telephone: 781-981-5407*  
*Fax: 781-981-0590*

To: VSRT Group  
 From: Alan E.E. Rogers  
 Subject: Measurements of the fraction of linear polarization

With a small amount of additional hardware it is possible to form an interferometer in which one element is sensitive to left circular polarization and the other is sensitive to right circular polarization. The “cross-polarization” interferometer is sensitive to linear polarization and has no response to unpolarized is the LNB feeds are perfectly circular. Figure 1 shows the VSRT configuration and highlights the added hardware needed to be able to switch from “co-pol” to “cross-pol”.

The following results were obtained using a GE “Biax” CFL (see memo #6):

Orientation of CFL	Co-pol	Cross-pol
CFL axis towards interferometer	210	11
CFL axis perpendicular to	92	45

The cross-pol response of the “end view” is presumably the result of imperfect circular feeds in the Direct TV feeds since by symmetry the linear polarization fraction should be zero.

The approximately 2:1 ratio between the co-pol and cross-pol looking at the “side-view” of the CFL corresponding to a linear polarization fraction of about 50%.

The statement in VSRT memo #38 that all the microwave radiation comes from collisions with the walls may not be quite correct as some may come from collisions in the plasma as the mean free path is estimated to be only about 1 cm (for a nominal 1 mm Hg pressure.) The detailed physics of the microwave radiation from CFLs needs further investigation.

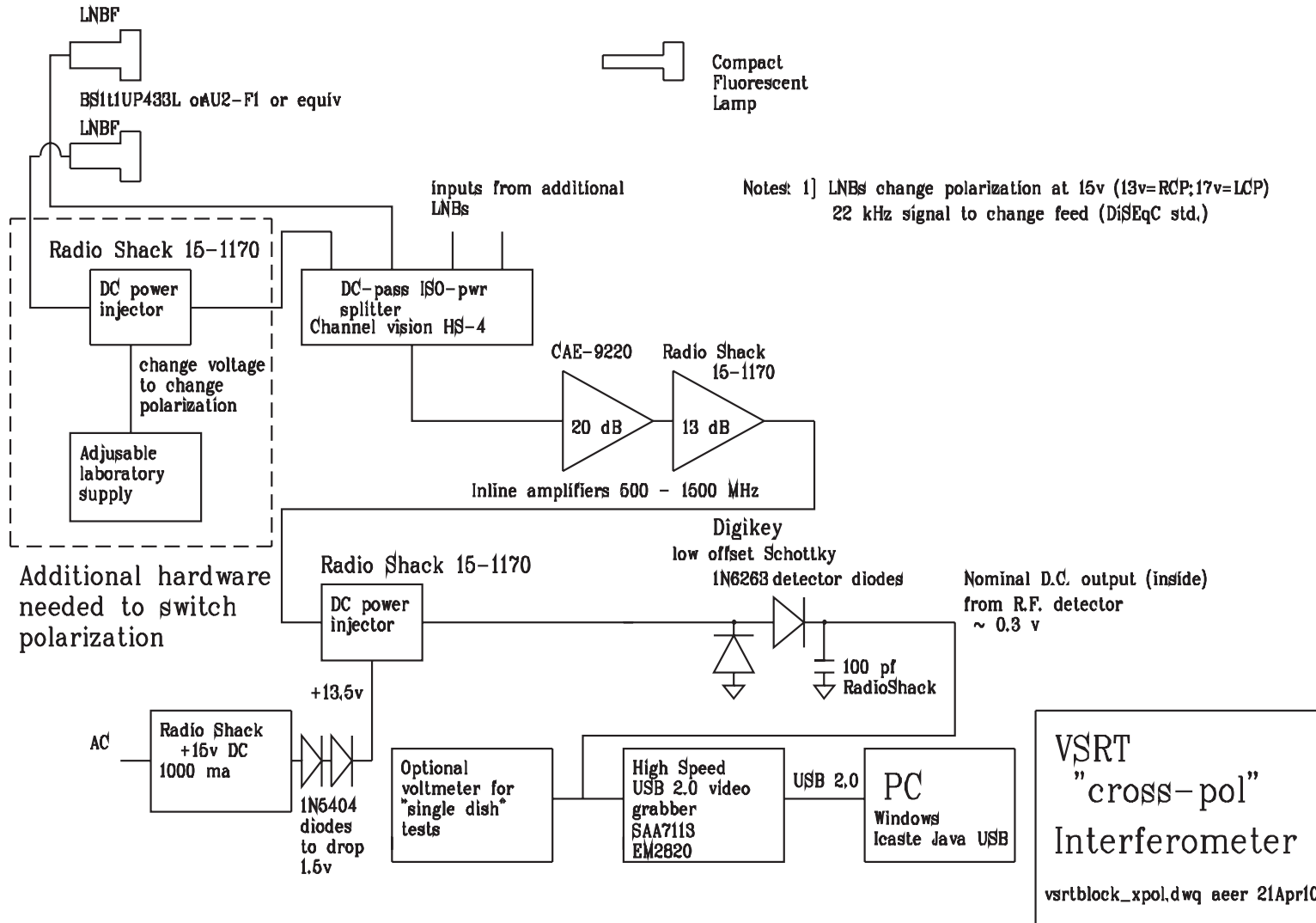

Figure 1. Block diagram of set-up to change polarization of one of the LNBFs.