

**MASSACHUSETTS INSTITUTE OF TECHNOLOGY**  
**HAYSTACK OBSERVATORY**  
**WESTFORD, MASSACHUSETTS 01886**  
 May 23, 2017

*Telephone: 617-715-5400*  
*Fax: 781-981-0590*

To: VSRT Group  
 From: Alan E.E. Rogers  
 Subject: Level of RFI emissions from Ozone spectrometer

The Ozone spectrometer along with the frequency calibrator were moved into the Haystack screen room and the signal levels were measured with a Agilent MXA N9020A 20 Hz to 26.5 GHz spectrum analyzer via an SMA feed through the metal wall into the next room.

First the signal levels of the calibrator were measured with it turned on all the time, and with a waveguide to SMA right on the calibrator probe (which is  $\frac{1}{4}$  wavelength long at 11 GHz). This setup is shown in Figure 1. The calibrator radiates at frequencies which are harmonics of 10 MHz. Table 1 give the measured level from 2 to 13 GHz.

Frequency GHz	Power dBm
2	-105
3	-100
4	-94
5	-94
6	-95
7	-95
8	-100
9	-110
10	-110
11	-110
12	-110
13	-120

Table 1. Power levels right at the calibrator probe.

Next the calibrator signal levels were measured with the calibrator probe 1 m away from a broadband Lindgren feed shown in Figure 2. The power levels were measured again. This time the levels were so low that the analyzer preamp was turned on and a narrow frequency window of 10 kHz was used. The results are listed in Table 2.

Frequency GHz	Power dBm
1	-130
1.2	-120
1.5	-110
2	-105
3	-125
4	-120
5	-113
7	-135
8	-137
9	-140
10	-140

Table 2. Levels from calibrator probe about 1 m from a broadband (1-15 GHz) feed.

Next a wide spectrum from 10 MHz to 12 GHz shown in Figure 3 was taken with about 3 minutes of averaging and a 3 MHz resolution. Some signals from the NUC are evident below about 5 GHz. There is a signal at 550 MHz that comes from the electronics and power supply associated with the chip scale atomic clock (CSAC) in this spectrometer. This signal can be reduced by 10 dB by adding an additional 04.7  $\mu$ F filter capacitor to the 12 volt D.C. power as shown in Figure 4. The signals every 10 MHz are completely unobservable in the broadband spectrum as they are about 10 dB below the -110 dB (300 K in 3 MHz) noise level of the broadband spectrum.

If there is any concern about the calibration signal in which each 10 MHz rail is more than 50 dB below then FCC part 15 limit of -49 dBm EIRP a Marki FB-1050 filter could be added at the output of the calibrator to keep the radiated signals within 7.55 and 13.35 GHz. The levels in Table 2 within 7 to 10 GHz are below  $3 \times 10^{-18} W/m^2$  at 100 m when all 3000 10 MHz harmonics are added. This is well below the limits for quiet zones at frequencies outside the radio astronomy bands. There could be an RFI concern within radio astronomy bands so the spectrometer should be more than 100 m from radio telescopes operating in the 7.55 to 13.35 GHz band. However, an ameliorating factor is that the calibration is only turned on about 1% of the time.

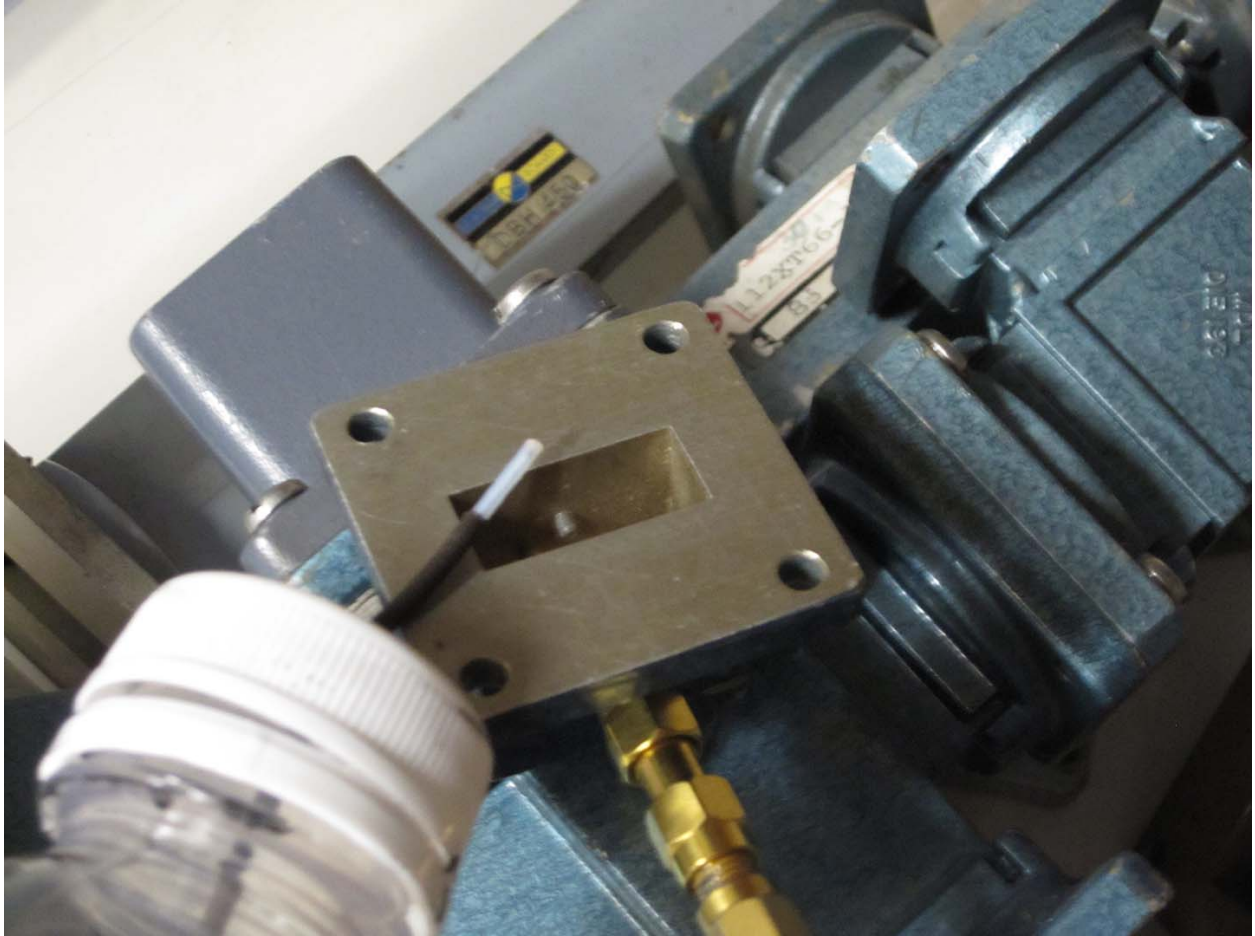

Figure 1. Calibrator probe coupled into coax to waveguide transition connected to spectrum analyzer.

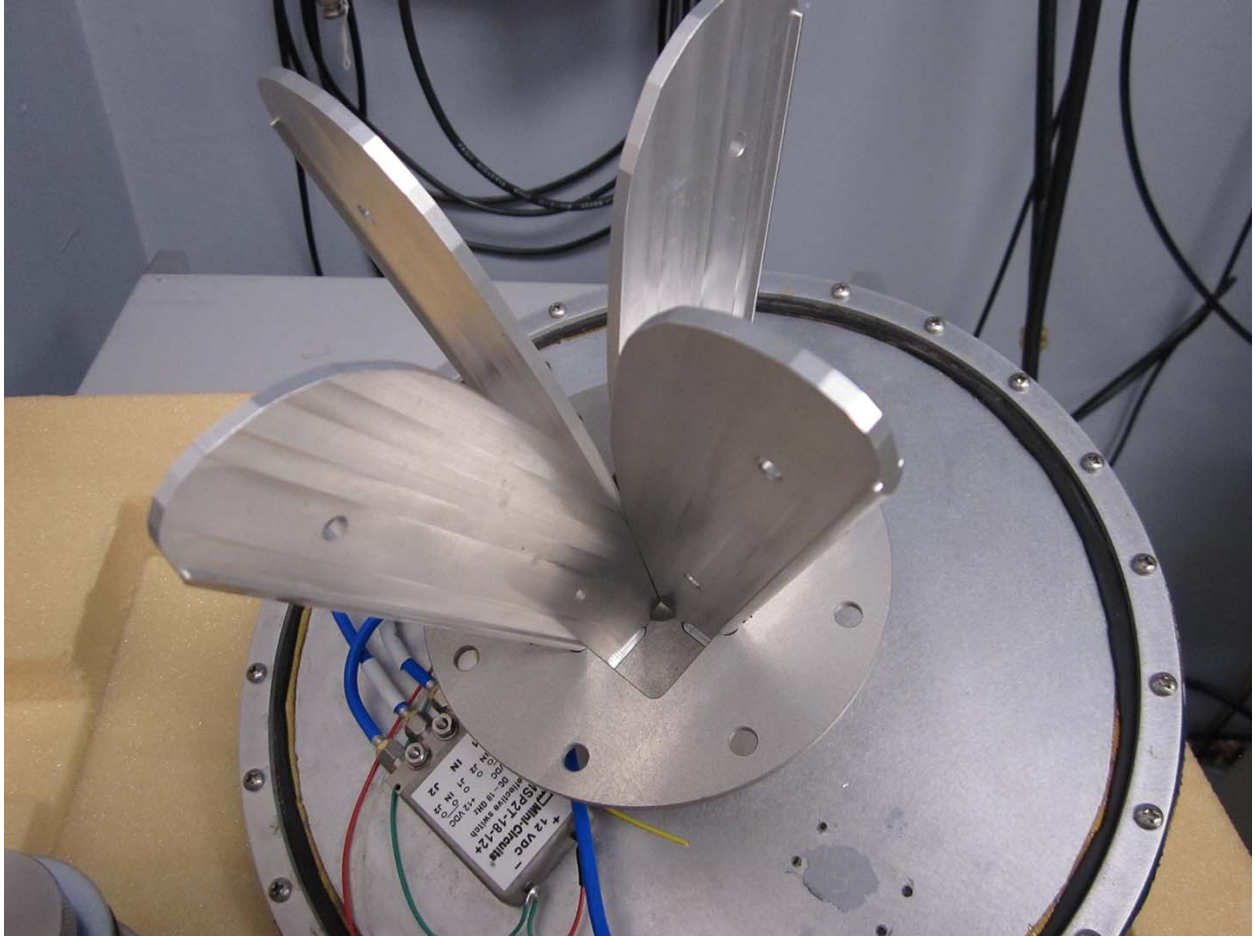

Figure 2. Wideband Lindgren feed used for measurement in screen room within about 1 m of ozone spectrometer and calibrator probe.

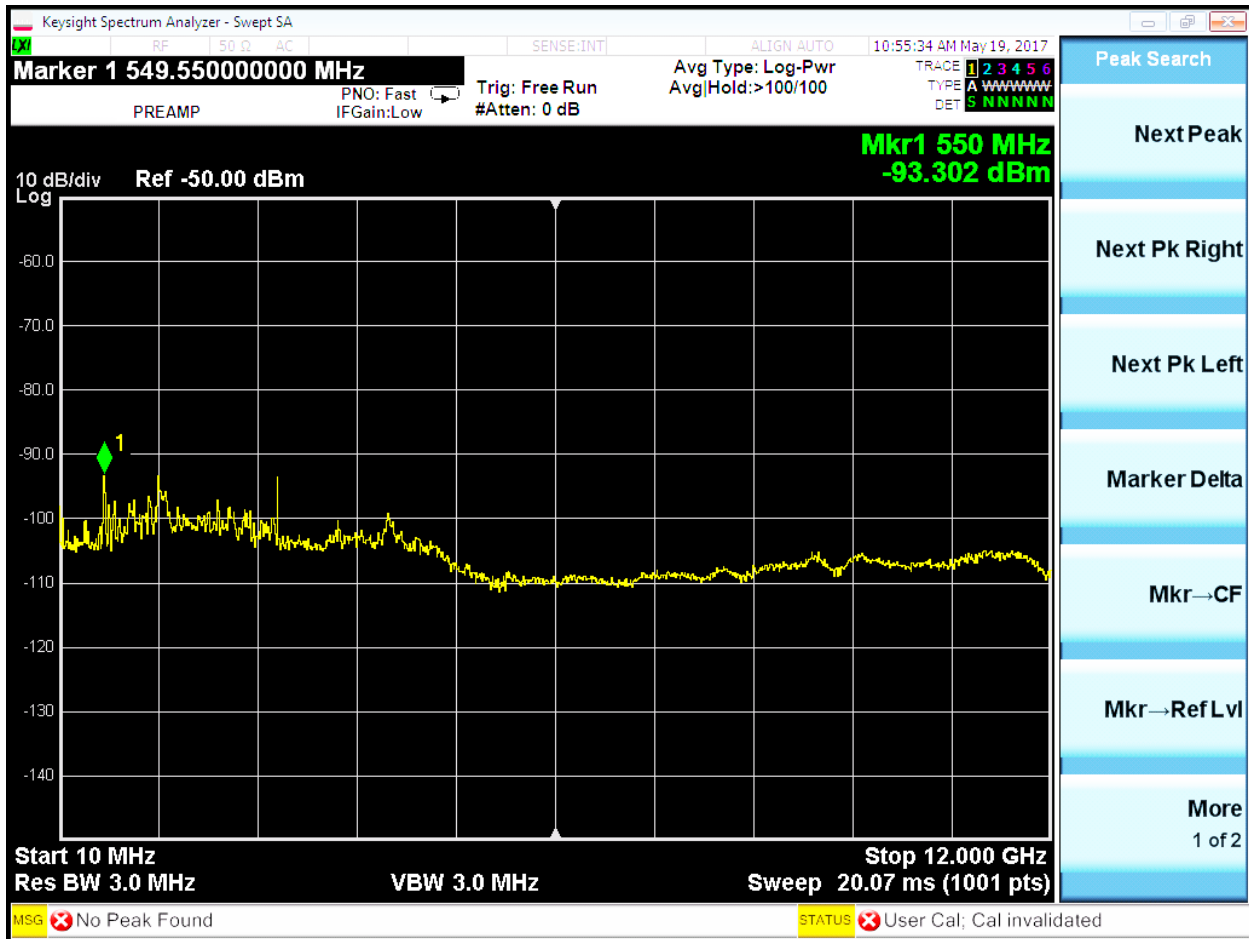

Figure 3. About 3 minutes of averaging of spectrum from Lindgren feed. Spectrum analyzer preamplifier is on.

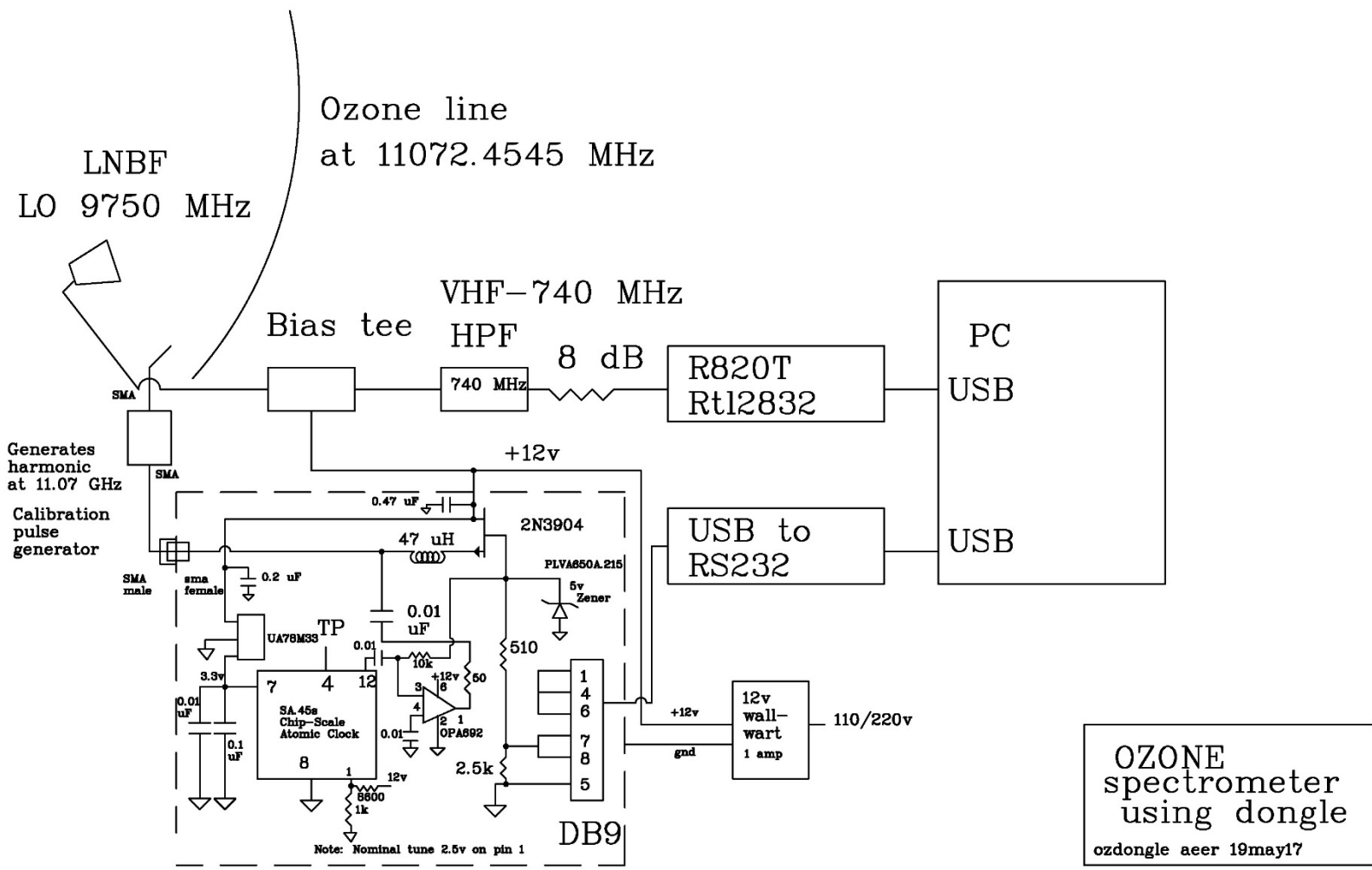

Figure 4. Circuit with added 0.47  $\mu$  F across + 12 volt supply.