

**MASSACHUSETTS INSTITUTE OF TECHNOLOGY
HAYSTACK OBSERVATORY
WESTFORD, MASSACHUSETTS 01886**

February 1, 2005

*Telephone: 978-692-4764
Fax: 781-981-0590*

To: RFI Group

From: Alan E.E. Rogers

Subject: Tests of Tektronix RSA3308A analyzer

We rented a RSA3308A with 20 dB preamp option 27 Jan 2005. I ran tests with the following parameters.

Ref. level	-20 dBm
R.F. atten	10 dB
Amplitude offset	20 dB (to correct for 20 dB preamp)
Start 30 MHz	stop 1500 MHz
Resolution BW	1 MHz
Filter Blackman Harris	default

The 650-A900-00 preamplifier was used. Figure 1 shows the block diagram ahead of the preamp.

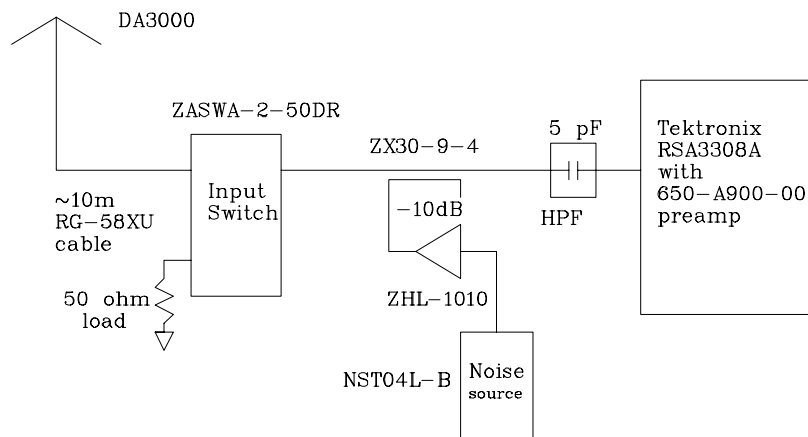

Figure 1 Calibration injection for Tektronix

An amplifier was used to boost the noise source output by 10 dB before going into the 10 dB coupler. The net noise output was checked using a calibrated signal generator set to equal the noise level output:

Frequency MHz	Signal output dBm	Equiv. noise dB
100	-93	21
500	-93	21
1000	-93	21
1495	-93	21

Note that the noise source and amplifier both had to be turned off for the noise to be turned off to avoid the added noise from the amplifier. The intermod distortion was tested using a signal generator and filter

Input signal freq. MHz	Level dBm	Ouput freq	Level dBm	IIP2/3
500	-30	1000	-90	+30
500	-20	1000	-70	+30
501 and 502	-13	500	-70	+15

The noise figure of the analyzer with preamp is about 6 dB. This is degraded to 10 dB \pm 1 dB when the loss in the noise injection coupler and input switch is included.

Data was acquired with 3 signal paths

1. Input switched to load “ref”
2. Input on load and noise on “ON”
3. Input on antenna “ant”

These 3 spectra allow full calibration of the noise temperature from the antenna since

$$P_{ant} = g(T_{ant} + T_{rec})$$

$$P_{ref} = g(T_{load} + T_{rec})$$

$$P_{on} = g(T_{cal} + T_{rec})$$

So that

$$T_{ant} = (T_{cal} - T_L) \left[\frac{P_{ant} - P_{ref}}{P_{on} - P_{ref}} \right] + T_L$$

where $T_{cal} = 40,000$ K

$$T_L = 300$$
 K

Figure 2 show a calibrated spectrum using the relation for T_{ant} given above. The dynamic range is close to 80 dB but the noise level is at about 300 K well above our goal of 1 K.

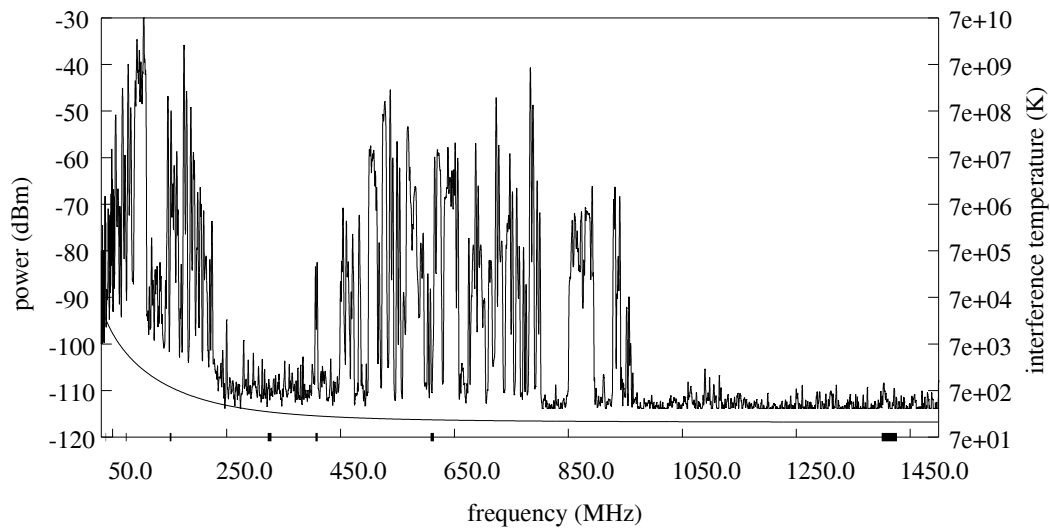

calibrated spectrum from Tektronix RSA3308A with preamp

Mon Jan 31 08:47:58 2005

The calibration electronics consists of an input switch and coupled noise source. The calibrated spectrum is made from a spectrum taken with a load, a spectrum with the load plus the added noise and a spectrum taken connected to a omni-directional antenna.

The signal strength is given in units of dBm and interference noise temperature for the 1 MHz resolution. The spectrum covers 30 to 1500 MHz. The antenna was located on the building which houses the 37 m antenna of the MIT Haystack Observatory. The bottom curve is the expected interference temperature for the combination of sky noise and ground pick-up. In this location the noise level in many of the passive bands is limited by a large number of electronic devices, like computers and network equipment which radiate signals at a level close to the FCC part 15 limit which is equivalent to an interference temperature at 300 MHz of about 6000 K in a 1 MHz bandwidth at a distance of 30 m.

The regions of relatively low signal can be compared with the allocations for the passive bands.

I suggest the next step is to put the input switch, coupler and noise source into a package with a USB interface. Then place the Tektronix and the calibration module in a RFI enclosure (only about 50 dB should be sufficient as the Tektronix is already a very quiet instrument) and locate the system in the RFI trailer of the D1 array which an environment comparatively free of RFI in the passive receive only bands. The cable loss of 25 feet of RG58 is about 3dB at 1 GHz so I recommend using a low loss heliax cable unless we can reduce the lengths or we should locate the calibration module at the antenna.

The current set-up is also limited by the losses in the antenna cable, input switch and coupler. The Tektronix spectral processing has about 0.2 dB rms sawtooth at the seams of the 20 MHz L.O. steps. The sawtooth is repeatable at a level of about 0.03 dB. The rms noise in 10 scans (which takes about 30 seconds) is 0.25 dB which is equivalent to an integration time of about 0.3 ms per point or about 1.5% efficiency with respect to a perfect 1 MHz scanning analyzer. (The NI is worse with even lower efficiency.)