

**MASSACHUSETTS INSTITUTE OF TECHNOLOGY
HAYSTACK OBSERVATORY
WESTFORD, MASSACHUSETTS 01886**

July 20, 2006

Telephone: 781-981-5407

Fax: 781-981-0590

To: RFI Group
From: Alan E.E. Rogers
Subject: EDGES and AC240 RFI monitor parameters

The EDGES electronics is split into two parts. The first part is the preamp (whose circuit is shown in Figure 1) which is located close to the antenna. The preamp gain is about 33 dB. The LNA whose noise temperature is about 20 K can be connected to the antenna, an ambient load and an ambient load plus calibration noise of about 500K. These states are selected via the supply voltage of 8,16 and 24 volts respectively. The second part is the “ground electronics” which provides additional amplification (circuit shown in Figure 2) and filtering. The overall gain is 66 dB and the 3 dB bandwidth extends from 50 to 330 MHz. With this gain and the AC240 fullscale set at 0.2 V peak to peak the ADC is very to clipping when the calibration noise is on. When used as an RFI monitor at a location like Haystack which has FM and TV signals at a level of about – 50 dB the gain has to be reduced by removing last amplifier (which reduces the gain by 23 dB to 43 dB), increasing the AC240 full scale to 0.5 volts and adding a 10 dB attenuator in front of the LNA.

Problems expected and those already encountered.

The goals of the EDGES is to measure the sky background in the range from 100 to 200 MHz with an absolute accuracy of better than 5 percent and to look for deviations in the smoothness of the spectrum, as seen in the residuals to a polynomial fit at a level of 100 ppm (10 mK out of 100 K) or better. Both of these goals are extremely challenging. The absolute accuracy is mainly expected to be limited by our ability to estimate the VSWR and ground losses in the antenna while the deviations in smoothness of the measured spectrum are expected to be limited by “stray” resonances like that shown in Figure 3 have already been seen in the preamp electronics and removed by change of components. In the case illustrated a chip capacitor with parallel resonance at 177 MHz was replaced. Another type of “stray” resonance was observed when the preamp was placed in a shielded box to remove local RFI from measurements on the bench. The preamp extended about 4 inches into the box and the inductance of the coax extension into the box together with the capacitance between the preamp assembly and the box produced a resonance just about 200 MHz. It is not yet clear if all resonances associated with the antenna and the cables, ground from etc. can be moved out of the 100-200 MHz band. Testing is not easy in a high RFI environment owing to the limit of the 8-bit ADC. Another problem which limits the dynamic range is a high level of pick-up of spurious signals from the digital electronics in the AC240. Fortunately these are relatively constant and cancel when the difference spectra are taken. However the degree of cancellation is poor when there is a large difference in the signal levels between the “signal” and “comparison” spectra. Testing in a screen room is likely

to be full of reflections and resonances. Testing in an anechoic chamber is a possibility. A possibility is driving to a place where the signals from FM and TV are about 40 dB weaker than at Haystack. There are certainly good sites within 5 hours driving, like West Forks, Maine.

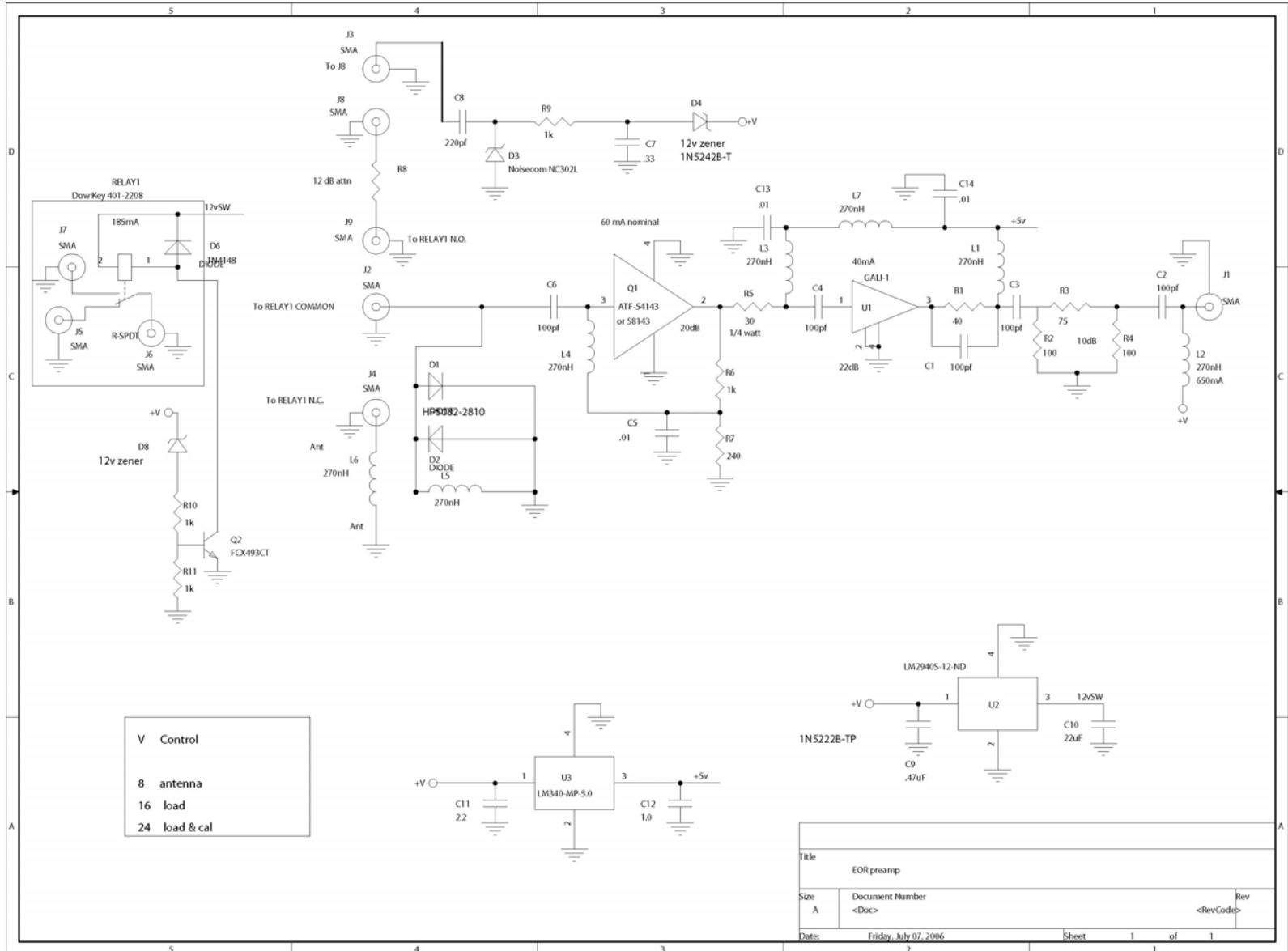

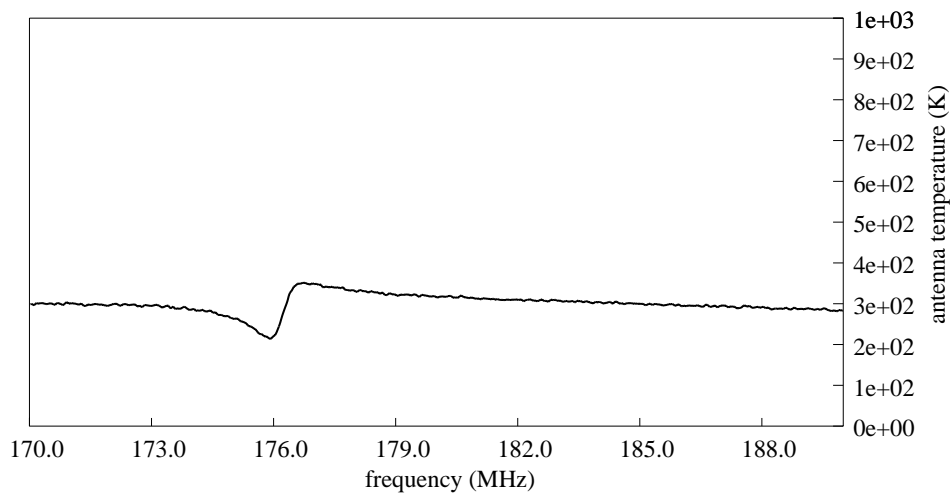
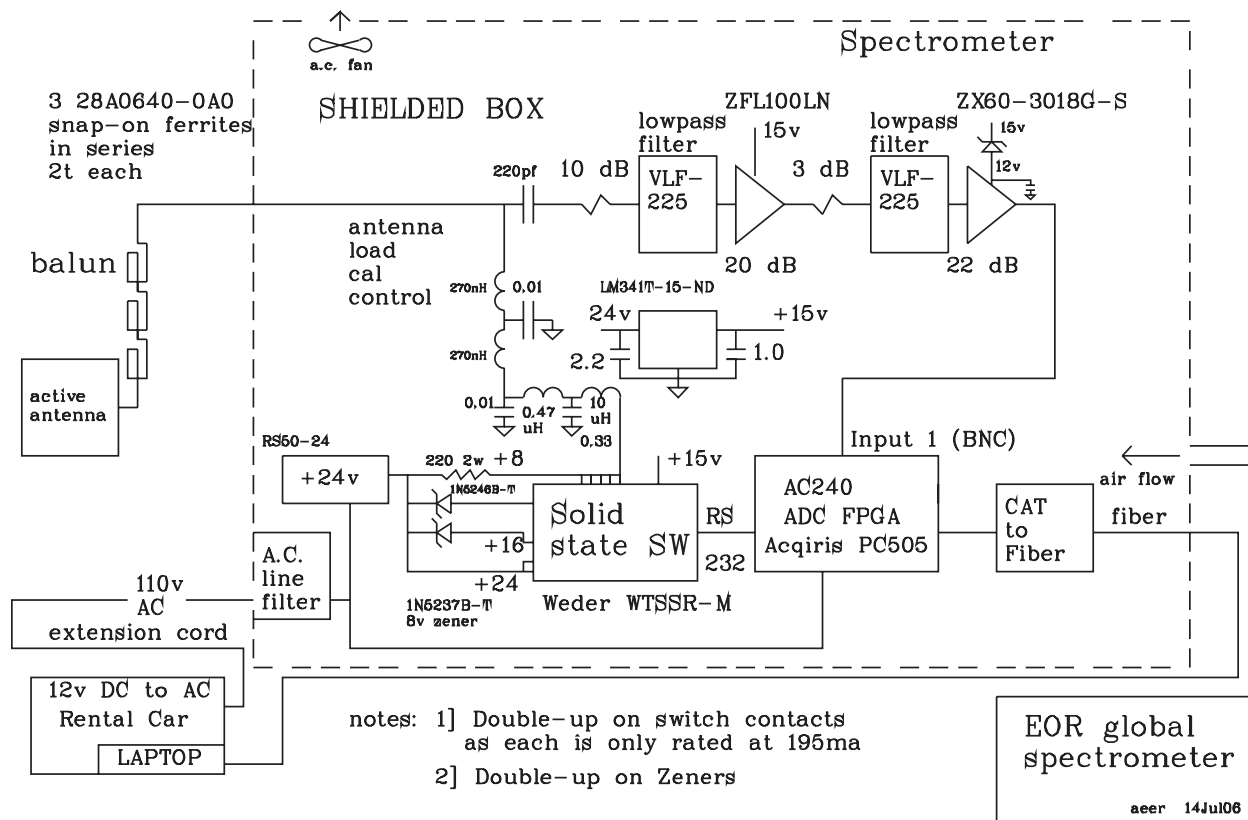

spectrum from Acqiris with preamp attn 0 fpgatm 39.3 degC
start 2006:183:18:13:22 stop 2006:183:18:18:52 resolution 122.0 kHz

Sun Jul 2 14:37:24 2006