

**MASSACHUSETTS INSTITUTE OF TECHNOLOGY
HAYSTACK OBSERVATORY
WESTFORD, MASSACHUSETTS 01886**

December 18, 2014

Telephone: 781-981-5400

Fax: 781-981-0590

To: EDGES Group

From: Alan E.E. Rogers

Subject: Changes to EDGES antenna to minimize frequency dependence of beam

In order to correct the beam shift resonance observed in the EDGES beam described in memo #150 and reduce the frequency dependence of the beam the tip capacitance has been reduced.

The effect of the tip capacitance is examined in memo #152 using FEKO. While lower values of tip capacitance improve the beam it becomes difficult to achieve a S11 below about -13 dB across the 100 to 190 MHz band. Figure 1 shows the best S11 that could be obtained. This was achieved with the following parameters.

- a) Tip capacitance set by $1 \times 0.75 \times 0.35$ " quartz set to maximum.
- b) Top cap design modified as per the drawing in Figure 2 using $1 \times 0.75 \times 0.25$ " quartz set to minimum and located 0.26 m from the base plate.

Sensitivity to mechanical effects

Lateral deflection from horizontal force on panels 1 mm/kg depends on tightness of nuts on threaded Nylon rods

S11 change 0.01 dB/mm at 190 MHz – less at lower frequency

Approx. sensitivity to mechanical change from FEKO

Fractional change to produce 0.01 dB (or 0.1 deg_of_phase)

0.3% in tip capacitance

0.1% in panel height

0.3% in panel gap

i.e. panel height is the most sensitive

One would expect the effect of temperature to be approximately 2×10^{-4} dB/K or a 50 K change needed to change the s11 by 0.01 dB based on thermal expansion of $20 \times 10^{-6}/K$ for Fiberglass

It is difficult to measure changes at Haystack using the radar splash plate because of the intermittent contact between the baseplate (which is now aluminum) and the splash plate. The change with lateral deflection was made by pulling back and forth on a string with tension of 10 lbs using a fish scale connected to a panel.

Comments:

- 1) When the antenna baseplate was located on the radar splash plate some resonances in the S11 were observed. These were eliminated by using copper tape as shown in Figure 3 to connect the 2 surfaces in places where there was a gap between the baseplate and the larger ground plane.
- 2) Recently large changes in S11 were observed in the EDGES antenna at the MRO following rain. These changes took more than a day to recover. The addition of a rain cover as shown in Figure 5 should prevent a slow recover from rain.
- 3) Consideration should be given to using a sealant at all the edges of the spacers between the panels and at the edges of the quartz parts to prevent water from being pulled by surface tension. Loctite 5145 sealant is recommended.
- 4) Following installation and tuning of the antenna the stability of the antenna could be tested by deliberately stressing the antenna with a non conducting pole or string to check for S11 changes. Following this check the effectiveness of the water sealant could be tested by adding the PET topcap cover and applying sealant to the edges on the spacers and quartz parts. After curing there should be no appreciable change in S11. Following this the antenna could be sprayed with water and the S11 recover time measured.

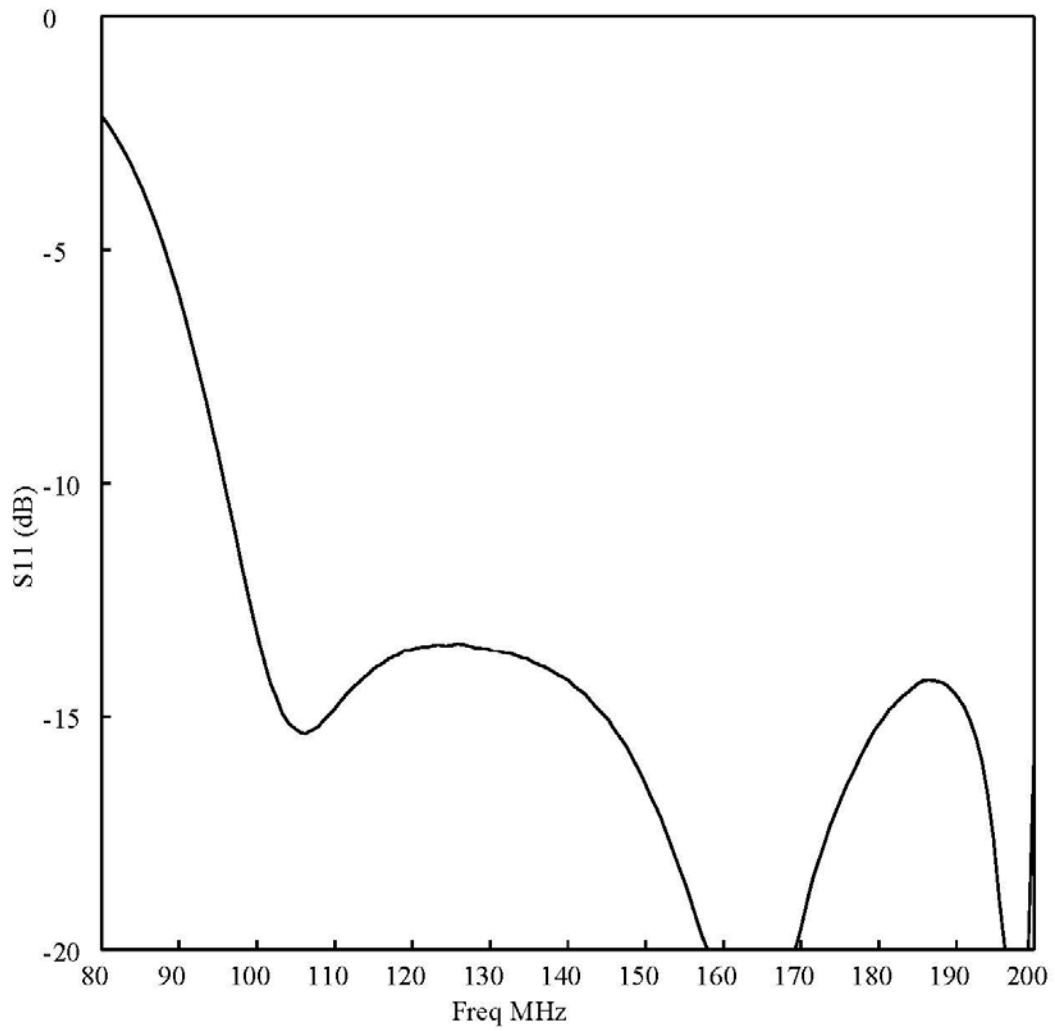

Figure 1. S11 of EDGES antenna with 1.4 *pf* tip capacitance measured at Haystack.

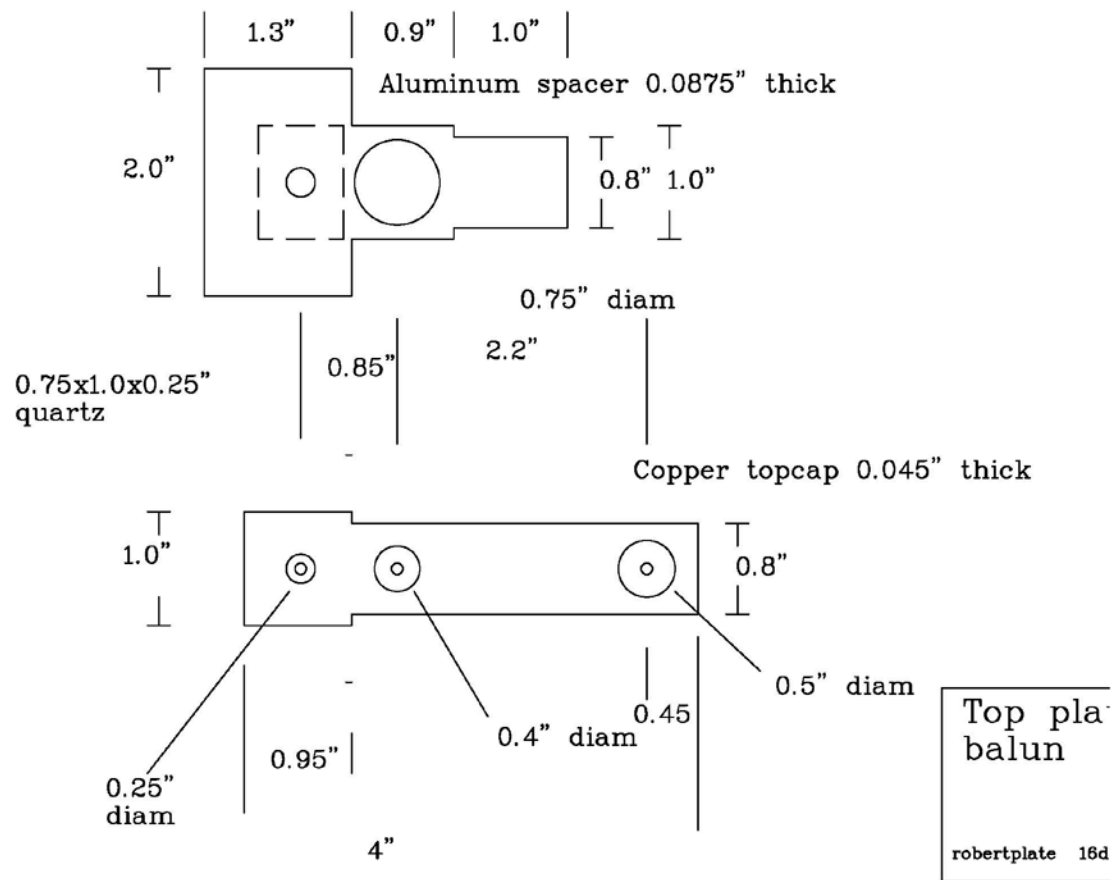

Figure 2. Revised top plate design

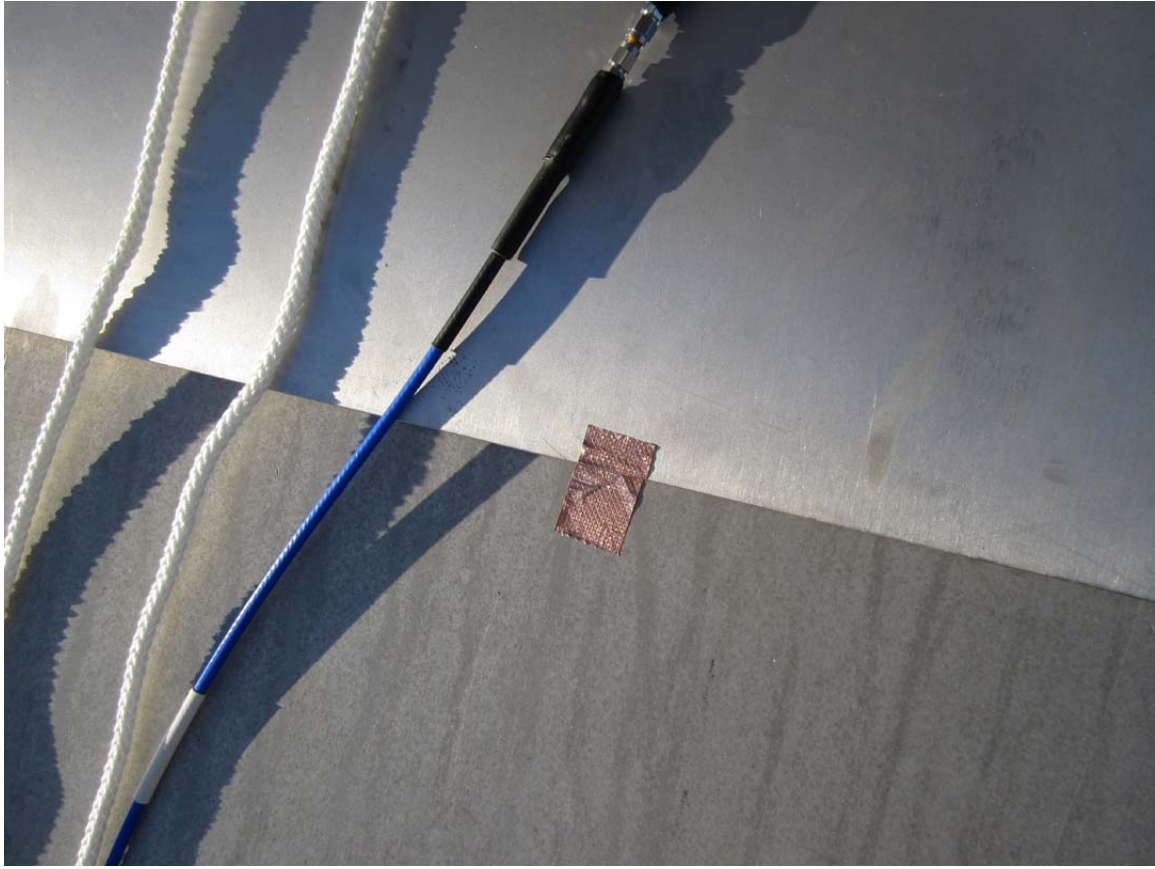

Figure 3. Copper tape between antenna baseplate and ground plane.

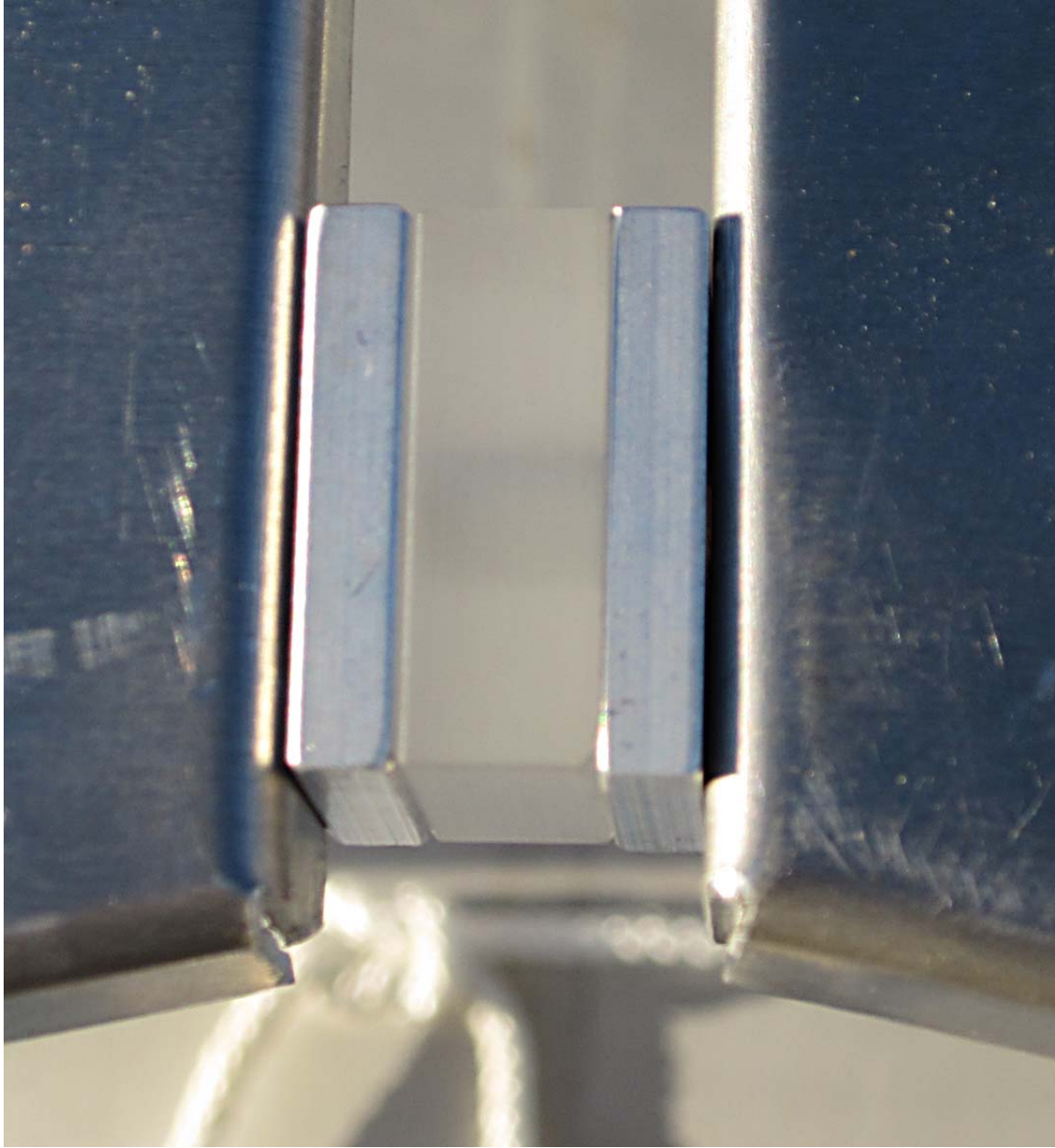

Figure 4. Quartz capacitor at “tip” of antenna panel.



Figure 5. PET rain cover for top plate.