

**MASSACHUSETTS INSTITUTE OF TECHNOLOGY  
HAYSTACK OBSERVATORY  
WESTFORD, MASSACHUSETTS 01886**

January 29, 2015

*Telephone: 781-981-5400*

*Fax: 781-981-0590*

To: EDGES Group

From: Alan E.E. Rogers

Subject: Tests of balun loss using active cold load

In memo 125 the balun loss dependence on the antenna S11 phase is shown to be the result of the complex impedance of the transmission line. Some bench tests of the theory were made and the results shown in memo 126. The full theory of the cable loss between the antenna and the LNA is given in memo 132. The measured loss of the high band antenna balun is given in memo 148. This memo also outlines some of the difficulties of the measurement due to the absence of a connector on the antenna end of the balun.

A sensitive lab test of the balun loss theory is made by using the EDGES receiver to measure the spectrum of a cold load. The use of a load whose temperature is well below ambient is useful as it allows confirmation of the theory of the noise contribution of the balun. The set-up used for this test is shown in the figure 1 along with a photograph in Figure 2. The cold load is formed by the input of a minicircuits ZX60-P103LN+ low noise amplifier.

Figure 3 shows the S11 of the amplifier input at the output of the balun via a SMA right angle bend. To avoid saturating the LNA the VNA output used for the measurement was set at -10 dBm. Figure 4 shows the calibrated output spectrum. This shows that the ZX60-P103LN+ puts out a noise level ranging from 120 K at 50 MHz down to 50 K at 190 MHz. Thus this amplifier forms a very convenient active cold load for laboratory tests. Also shown in Figure 4 is a plot of the residuals to a 4 term polynomial. The rms residual of 45 mK is only achieved with the balun loss correction using the method described in the following section on the theory. Figure 5 shows the residuals without balun loss correction.

An alternate method is to consider the path from the EDGES reference plane to the antenna as 2 or 3 transmission lines in cascade whose S-parameters can be obtained by converting S to T parameters performing the multiplication and converting back from T to S parameter matrices. This method allows the separate parts to be measured or modeled. In practice this method is most useful for modeling. Modeling shows that the section close to the EDGES reference plane has the largest influence on the loss. Further the loss of SMA bends and short SMA cables is much higher than expected because the thickness of gold or silver plating intended to reduce the loss is inadequate for the low frequency range. This is discussed in memo 148.

## Theory

The reflection coefficient of the antenna,  $\Gamma_a$ , which in this case in the minicircuits LNA can be calculated from the reflection coefficient,  $S_{11a}$ , of the antenna measured through the balun from the reference plane of the EDGES spectrometer.

$$\Gamma_a = (S_{11a} - S_{11}) / (S_{12}S_{21} - S_{11}S_{22} + S_{11a})$$

Where  $S_{11}$ ,  $S_{12}$ ,  $S_{21}$  and  $S_{22}$  are the S-parameters of the balun plus the SMA bends on either end.  $S_{11}$  in the reflection towards the antenna.

The loss is calculated from

$$L = |S_{12}S_{21}|(1 - |\Gamma_a|^2) / \left( (1 - |S_{11a}|^2) |1 - S_{22}\Gamma_a|^2 \right)$$

The S-parameters can be measured with a single port VNA by making 3 measurements of 3 known loads placed at the end

$$T_{measured} = S_{11} + S_{12}S_{21}\Gamma_\ell / (1 - S_{22}\Gamma_\ell)$$

Where  $\Gamma_\ell$  is known loads. 3 different loads provided 3 equations from which  $S_{11}$ ,  $S_{12}S_{21}$  and  $S_{22}$  can be obtained. In the case of a real antenna it may be difficult to connect the loads, although an attempt to do this is described in memo 148.

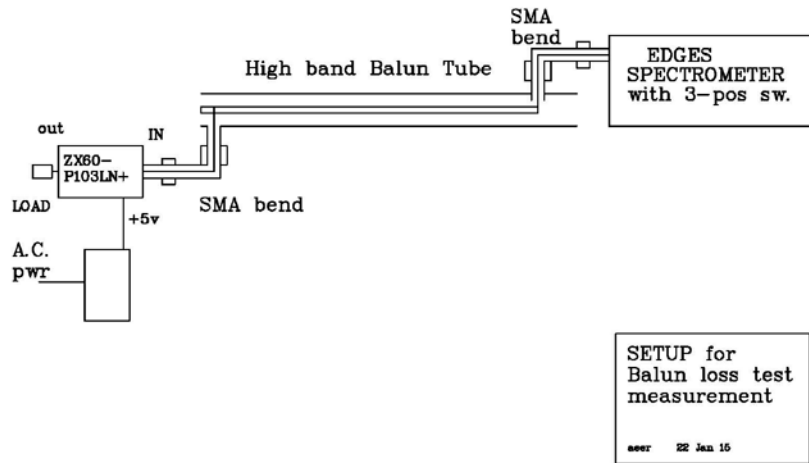

Figure 1. Block diagram of the connection of an active cold load via the EDGES balun to the EDGES calibrated spectrometer.

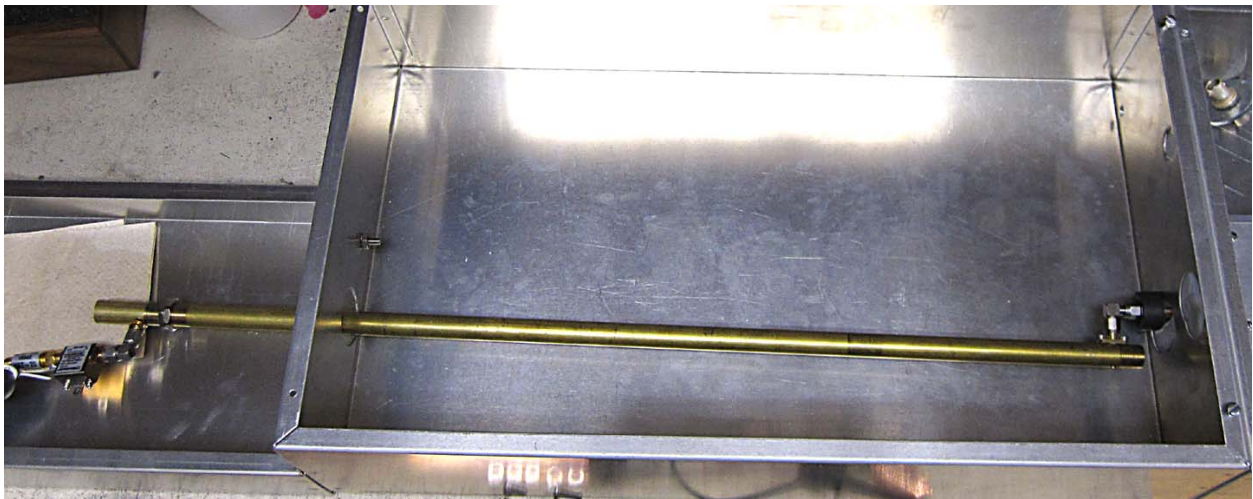

Figure 2. Photo of minicircuits LNA input connected to EDGES spectrometer via balun.

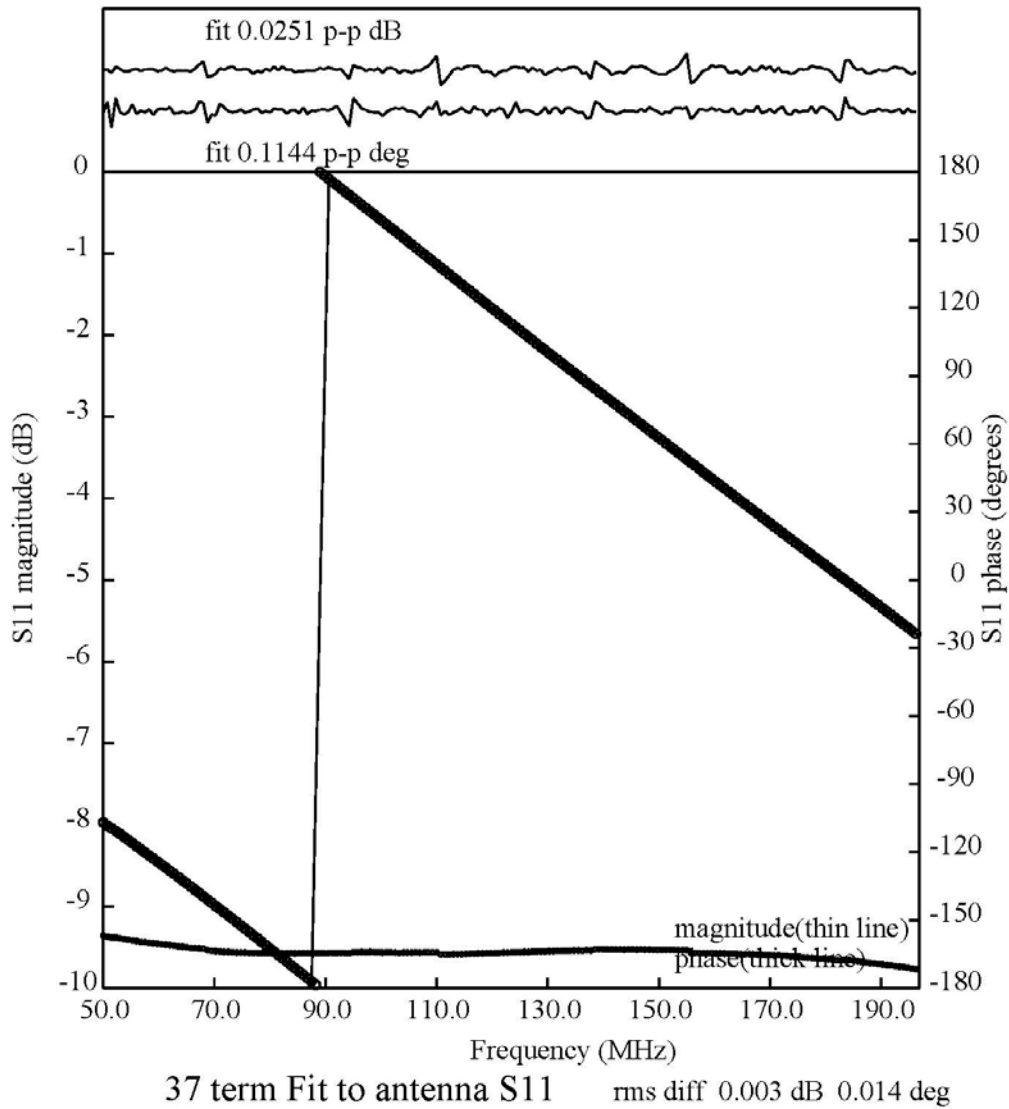

Figure 3. S11 measured towards active cold load from EDGES reference plane.

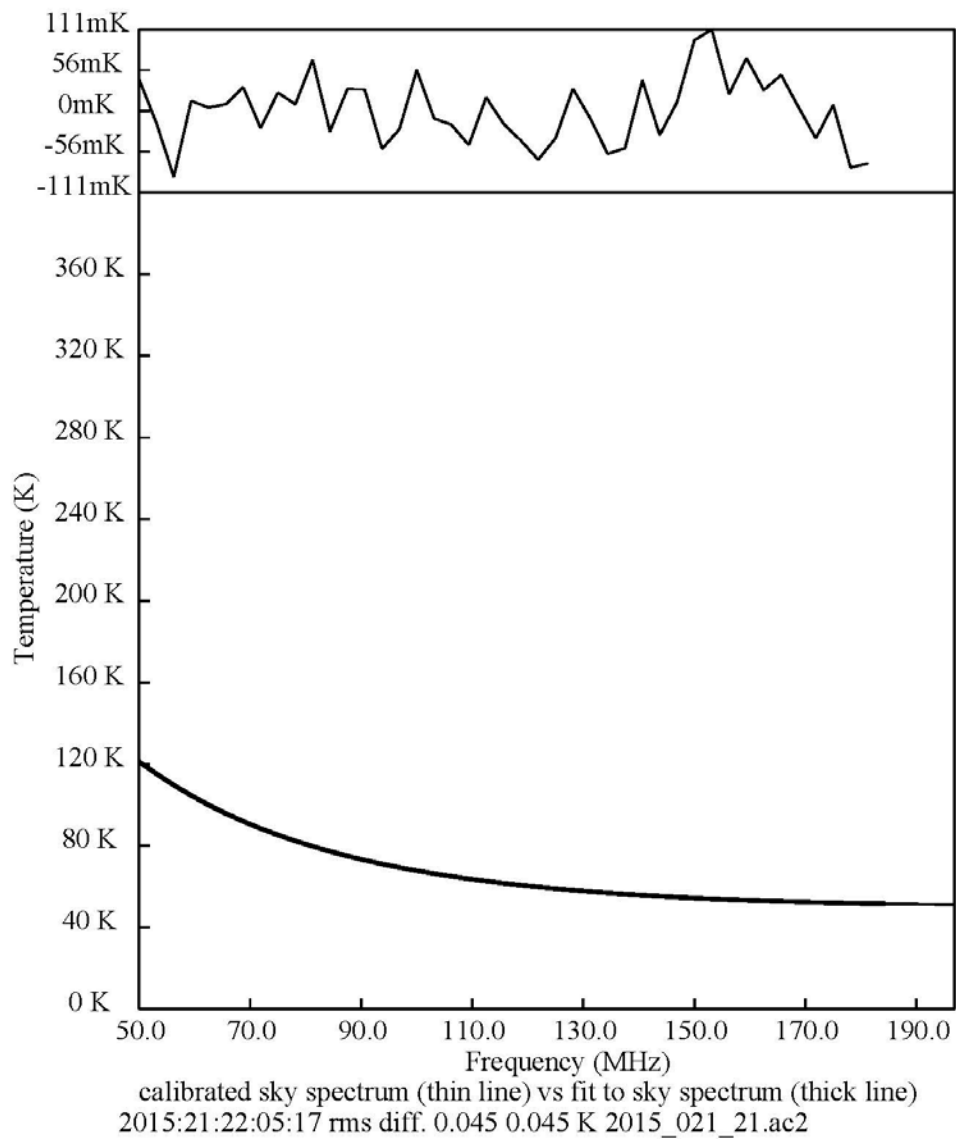

Figure 4. Calibrated spectrum along with residuals to 4 term polynomial

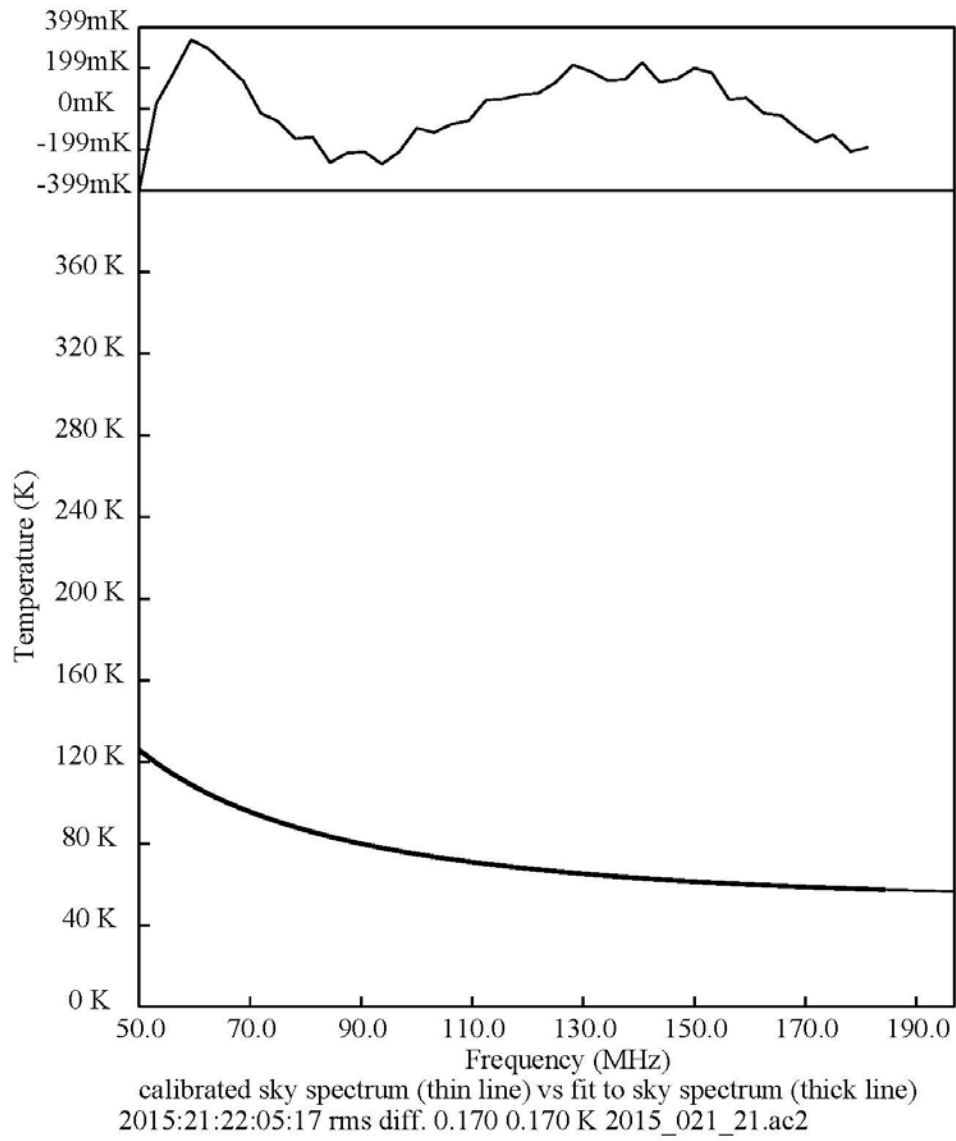

Figure 5. Residuals without balun correction.