

**MASSACHUSETTS INSTITUTE OF TECHNOLOGY  
HAYSTACK OBSERVATORY  
WESTFORD, MASSACHUSETTS 01886**

May 10, 2016

Telephone: 781-981-5414

Fax: 781-981-0590

To: EDGES Group  
From: Alan E.E. Rogers  
Subject: Artificial antenna simulator

A new “artificial Antenna” simulator has been designed with an output more closely representing the foreground. It consists of a noise source followed by a single pole low pass filter using a 560 nH inductor.

The block diagram and noise diode circuit is shown in Figure 1. An optional 6 dB attenuator followed by a 10 ft cable coiled into a metal box are added to provide a spectrum and S11 similar to the sky in the 50 to 200 MHz range. The output spectrum is approximately 2000 K at 50 MHz dropping 6 dB per octave to 130 K at 200 MHz but can be raised or lowered using different values of attenuation. If treated as an antenna a spectrum can be obtained using the reflection coefficient measured at the receiver input reference plane. If a passive 2-port network is added to the output of the simulator and another spectrum obtained this spectrum should be the same as the first if a loss correction is made using the relations in memo #132. That is.

$$L = \left(1 - |\Gamma_a|^2\right)^{-1} |S_{21}|^2 \left(1 - |\Gamma|^2\right) / |1 - S_{22}\Gamma|^2$$

where  $\Gamma = (\Gamma_a - S_{11}) / (S_{12}S_{21} - S_{11}S_{22} + S_{22}\Gamma_a)$

where  $\Gamma_a$  is antenna reflection coefficient measured looking into the antenna with the added 2-port whose s-parameters are S11, S12, S21, S22.

For example the first spectrum might be made with the 6 dB followed by the low pass following the noise source and the second spectrum by adding the cable box before the 6 dB attenuator. Another combination might use a 3 dB attenuator instead of the 6 dB to check a higher signal level. Yet another might just use a 3 dB adding another 3 dB instead of the cable box for the second spectrum. In all cases the spectra are expected to have a smooth spectrum since the noise diode is smooth and relatively flat. Examples of noise diode spectra are discussed in memos 68, 73 and 81.

Figure 2 shows the noise source connected through the low pass filter followed by a 6 dB attenuator and the cable in a box. The S11 of this combination is shown in Figure 4.

#### *Tests of the stability of the cable*

The S11 of the cable box with one port open is shown in Figure 5. In order to measure the stability of the cable it was connected to the VNA as shown in Figure 3. A soldering iron was attached and turned on for 3 minutes to heat the cable box to 30°C from the ambient 25°C room. Following

stabilization of the temperature at 28°C after about another 10 minutes the S11 became more negative by 0.002 dB at 50 MHz and 0.004 dB at 200 MHz. Any ripple was less than 0.002 dB peak to peak. After another 1 hour the temperature returned to 25°C and the S11 to within 0.001 dB of the starting point. In the same test the 20 ns delay increased by 1 picosecond at 25°C and returned to zero at 25°C. This corresponds to a cable delay temperature coefficient of about 17 ppm/°C.

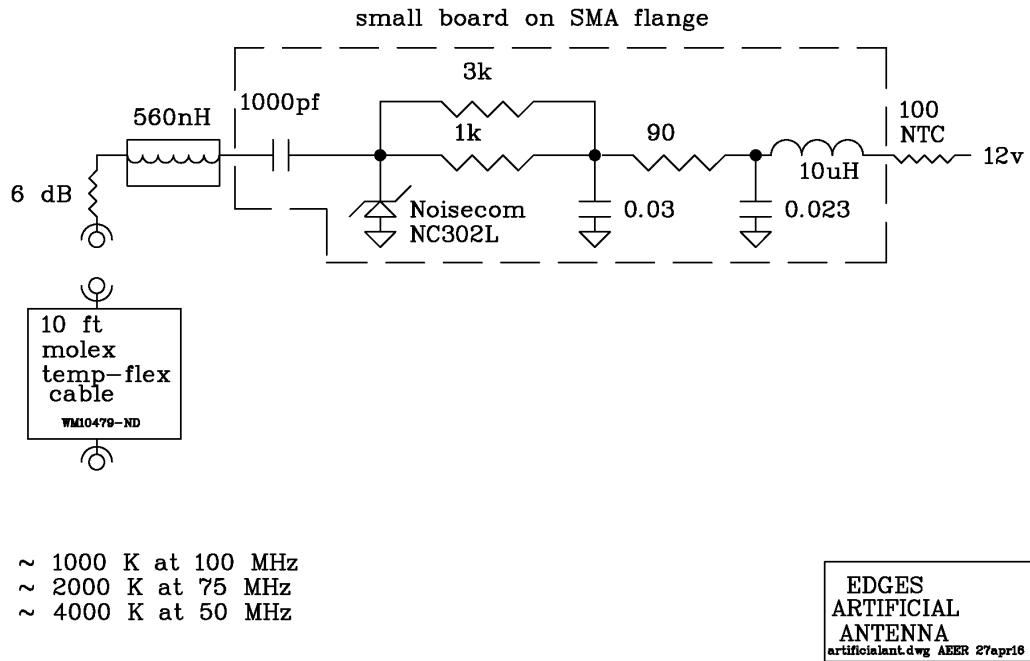

Figure 1.

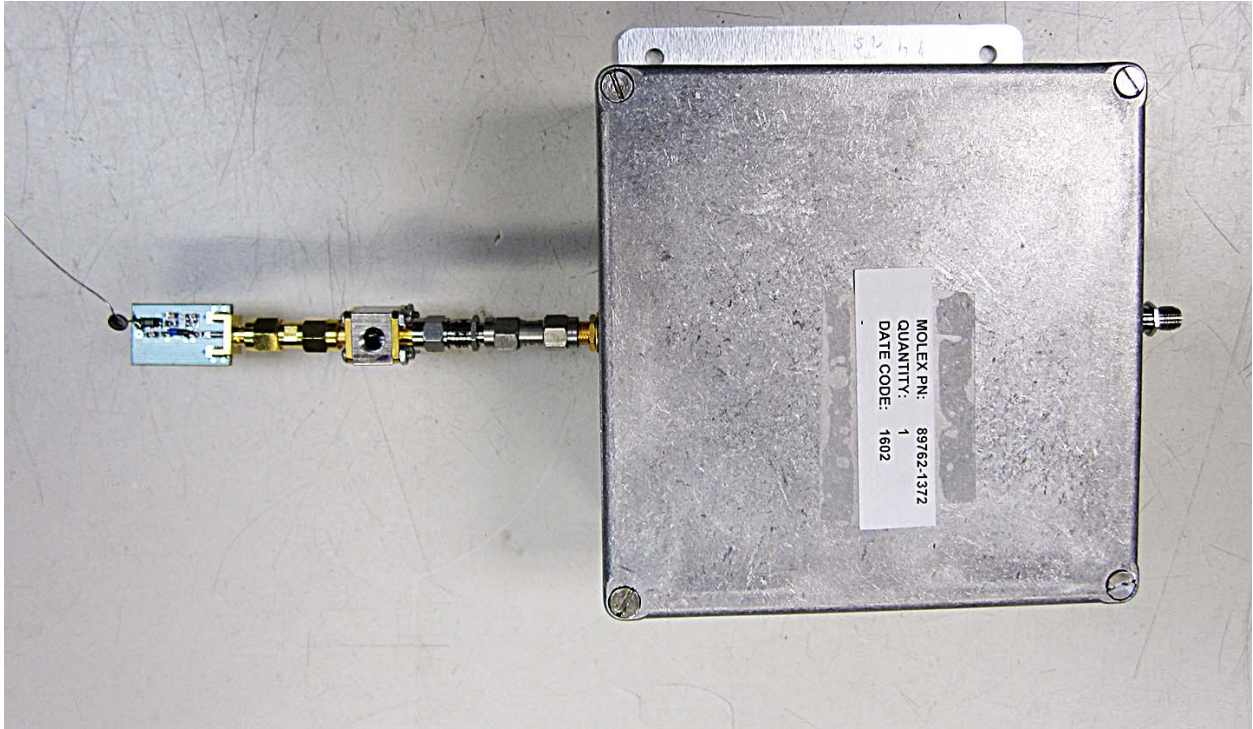
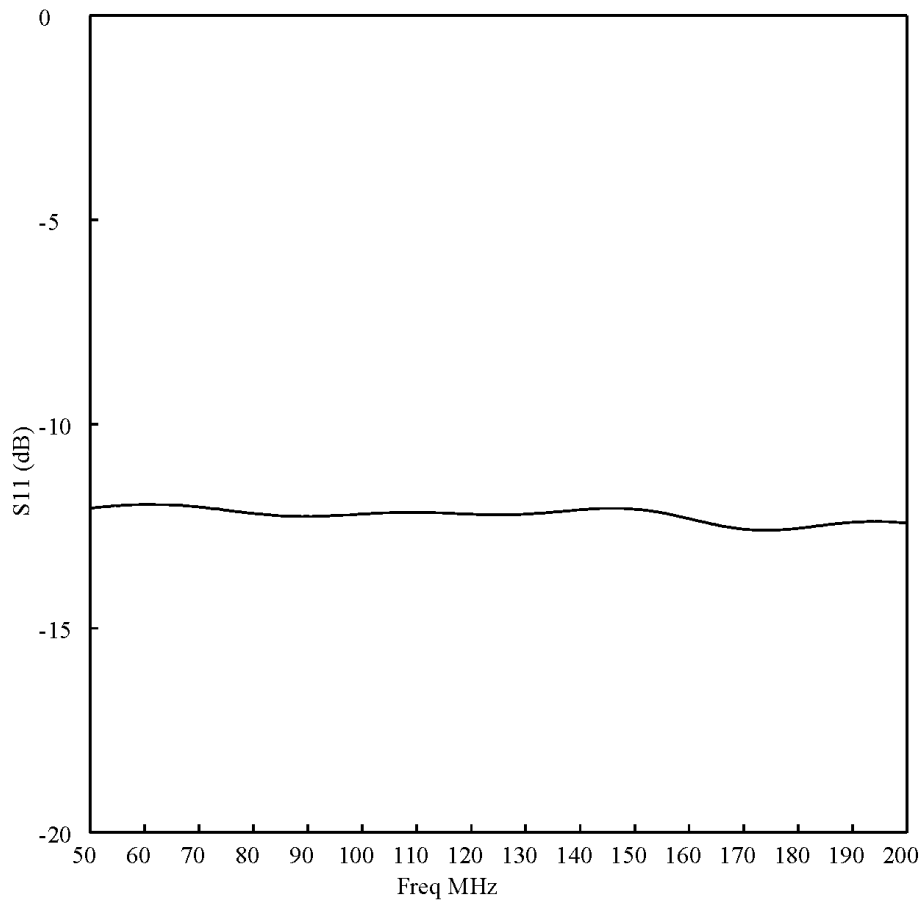

Figure 2. Noise source followed by low pass filter, 6 dB attenuator and box with 10 ft cable.

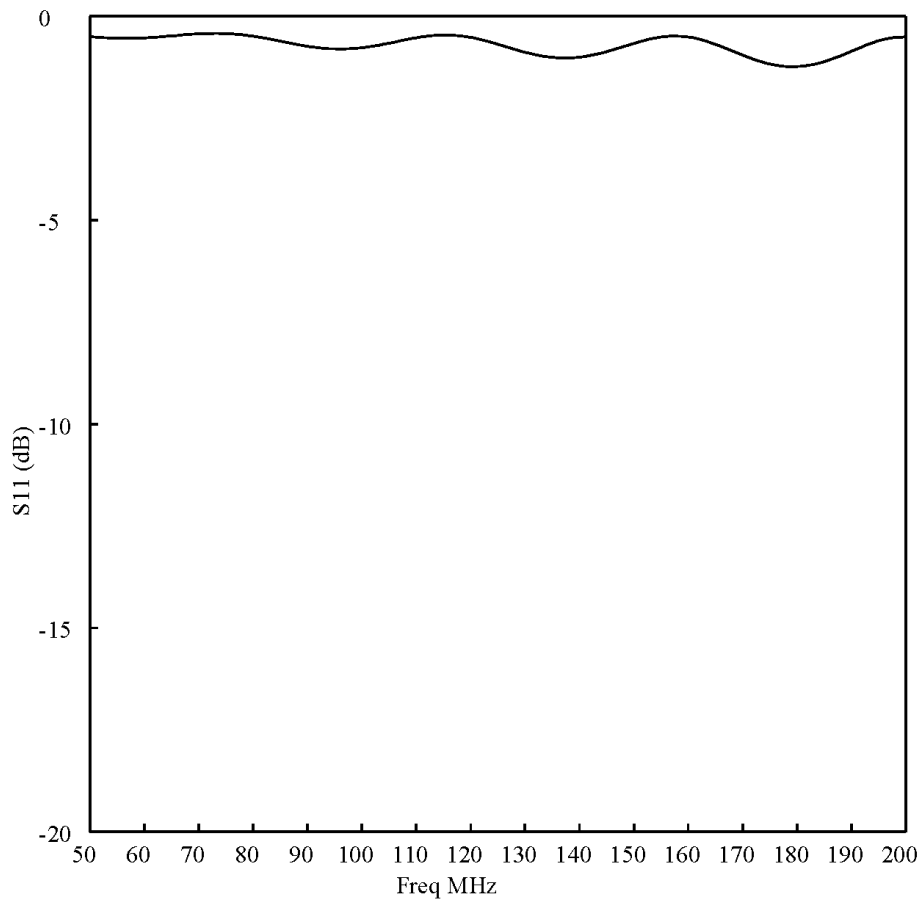

Figure 3. Cable attached to VNA port.



file:/home/aecer/eor/noise.csv

Figure 4. S11 of noise source through cable and 6 dB attenuator.



file:/home/aer/eor/noise2.csv

Figure 5. S11 of open cable.