

MASSACHUSETTS INSTITUTE OF TECHNOLOGY
HAYSTACK OBSERVATORY
WESTFORD, MASSACHUSETTS 01886
 February 14, 2006

Telephone: 781-981-5407
Fax: 781-981-0590

To: RFI Group
 From: Alan E.E. Rogers
 Subject: Absolute calibration of an active antenna

The antenna temperature can be accurately calibrated by 3 position switching (see memo 21) provided the antenna is perfectly matched. Obtaining a perfect match over a wide range of frequencies is very difficult. A mismatched antenna results in 2 problems. First the power received by the LNA is reduced by the factor $1-|\Gamma|^2$ and second the noise contribution of the LNA is altered by the match. This second problem could be fixed by using an isolator but isolators have limited bandwidth. In the measurements of the Galactic and Cosmic background made in the 1960s great care was taken to obtain a perfect match using a VSWR matching tuner. However this technique only works for a single frequency unless the matching network can be made broadband or an inefficient scanning spectrometer is used with a tunable matching filter that tracks along with the scanning analyzer.

While a broadband isolator or circulator is not available to cover the 100-200 MHz range consider placing a 3 port circulator in front of the LNA and an input switch. In this case if we make 4 power measurements as follows:

- 1] Connect to the antenna

$$P_o = \left(T_a (1 - |\Gamma|^2) + T_{amb} |\Gamma|^2 + T_r \right) g$$

where T_a = antenna temperature

Γ = antenna reflection coefficient

T_{amb} = temperature of load on port 3 of isolator

T_r = receiver noise temperature

g = gain

- 2] Turn on noise source on port 3 of isolator

$$P_1 = \left(T_a (1 - |\Gamma|^2) + (T_{amb} + T_{ns2}) |\Gamma|^2 + T_r \right) g$$

where T_{ns2} = noise source temperature on point port 3

- 3] Connect input to load

$$P_2 = (T_{amb} + T_r) g$$

4] Connect input to noise source

$$P_3 = (T_{ns1} + T_{amp} + T_r)g$$

where T_{ns1} = noise source temperature

from these measurements

$$a = P_1 - P_0 = gT_{ns2}|\Gamma|^2$$

$$b = P_3 - P_2 = gT_{ns1}$$

$$c = P_0 - P_2 = g(T_a - T_{amb})(1 - |\Gamma|^2)$$

From which

$$T_a = T_{amb} + c(T_{ns1}/b) / (1 - a(T_{ns1}/b)/T_{ns2})$$

As an alternate to using an isolator a directional coupler can be used to launch a noise signal to the antenna to measure the reflection coefficient while balanced amplifiers with quadrature hybrids on the input and output can be used to cancel the reflective amplifier noise.

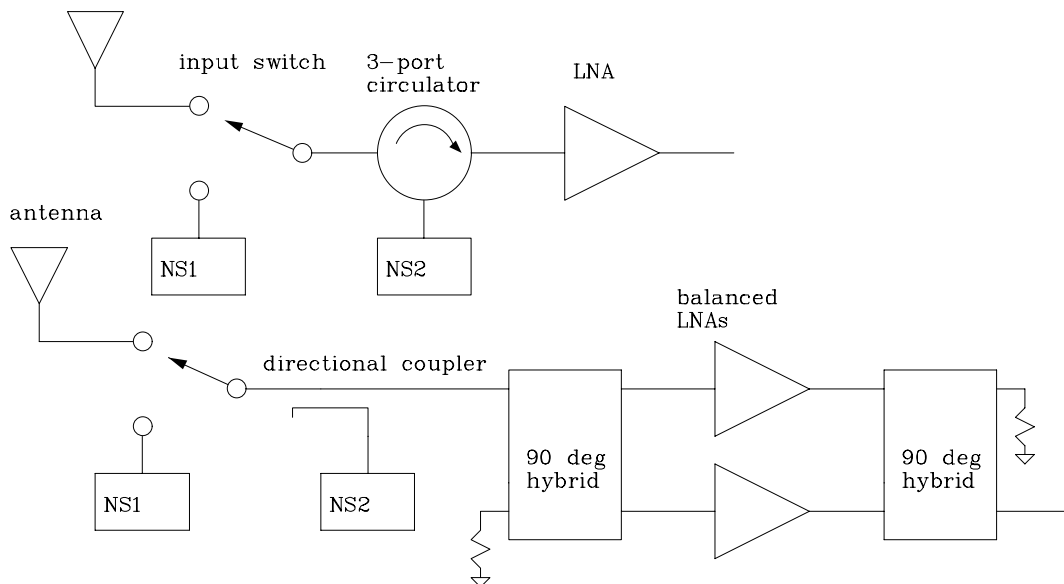

Notes: 1] Assumes noise sources NS1 and NS2 have been calibrated

Figure. Two schemes for absolute antenna calibration